

TQMa6ULxL

Energy efficient with future CPU architecture

The Minimodule TQMa6ULxL, based on the i.MX6UL and iMX6ULL from NXP, combines the ARM Cortex-A7 core technology with a variety of interfaces. The LGA module has been developed especially for the use in high volume projects. The integrated graphics controller supports applications with display and touch screen requirements. TQMa6ULxL is best suited for various applications such as industrial automation and controls with requirements for low power and secure data processing. There are six CPU variants available. With a Single Cortex™-A7 core and a clock rate up to 528 MHz the TQMa6ULxL provides a balanced ratio between applications for visualization and control performance and power dissipation. All the processor's functional pins are on the LGA pins.

The highlights:

- Graphic
- Extended temperature range
- 2x Ethernet with IEEE1588
- Low power consumption (typ. 1 W)
- Camera sensor interface
- Security functions
- Long term availability

Block Diagram TQMa6ULxL

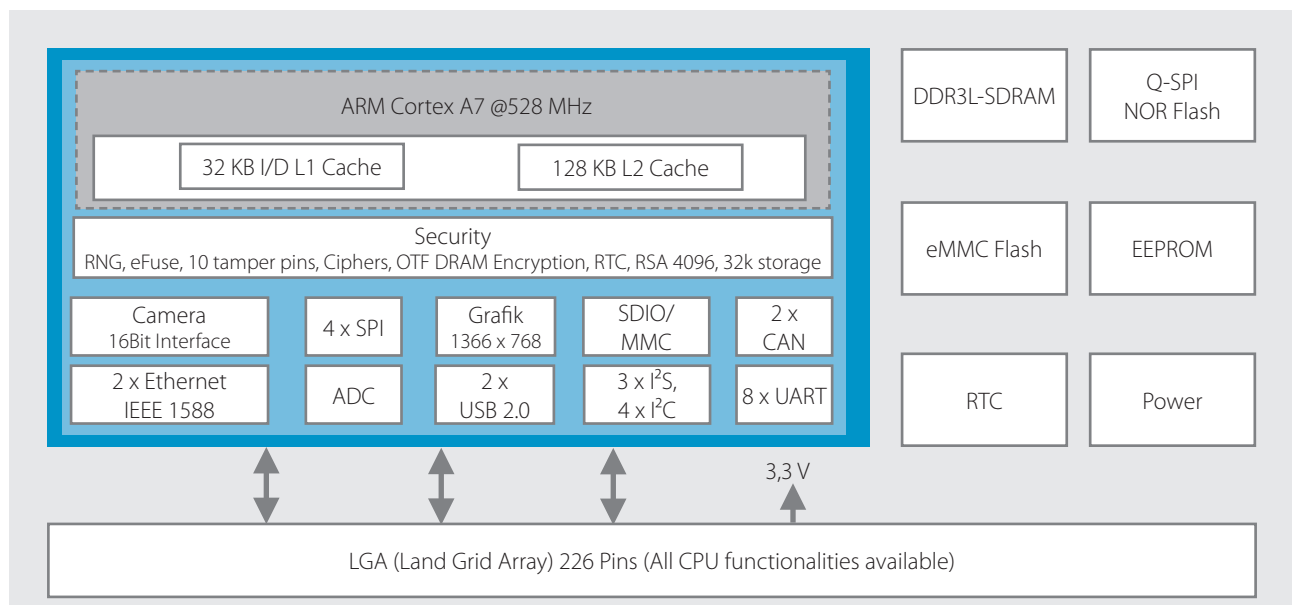

Technical specification

Microprocessor

i.MX6UL (G1, G2, G3)
i.MX6ULL (Y0, Y1, Y2)

System interfaces

Up to 2x Ethernet 10/100 Mbit
Up to 2x CAN
Up to 2x USB 2.0 high speed OTG interface
Up to 8x UART

Periphery interfaces

Up to 2x SDIO/MMC
Up to 4x I²C
Up to 4x SPI
Up to 3x I²S

Graphic

LCD Interface (24 Bit RGB)
1 x 16 Bit Camera Sensor Interface

Memory

DDR3L-SDRAM: Up to 1 GB
Quad SPI NOR: Up to 256 MB
Up to 32 GB eMMC-Flash
EEPROM: 0 / 64 kbit

Other

Real Time Clock (RTC)
Temperature sensor
CPU JTAG Interface

Power supply

3,3 V

Ambient conditions

Standard temperature range: -25°C...+85°C
Extended temperature range: -40°C...+85°C

Dimensions

38 mm x 38 mm

Plug-in system

LGA (Land Grid Array) 226 Pins

Operating systems

Linux

Operating systems on request

VxWorks, QNX

Ordering information

TQMa6UL1L-AA (Prototypes Q1/2017)

TQMa6UL1, Cortex-A7 / 528 MHz, 4 GB eMMC Flash
256MB DDR3L, 64 kB EEPROM, -25°C ...+85°C

TQMa6UL2L-AA (Prototypes Q1/2017)

TQMa6UL2, Cortex-A7 / 528 MHz, 4 GB eMMC Flash
256MB DDR3L, 64 kB EEPROM, -25°C ...+85°C

TQMa6UL3L-AA (Prototypes Q1/2017)

TQMa6UL3, Cortex-A7 / 528 MHz, 4 GB eMMC Flash
256 MB DDR3L, 64 kB EEPROM, -25°C ...+85°C

Further variants on request.

STKa6ULx-AA

STKa6 (Eval Kit) with TQMa6ULx-AA, Cortex-A7 / 528 MHz, 256 MB DDR3L, 4 GB eMMC Flash, 64 kB EEPROM, 1x RS232, 1x RS485, 2 x CAN 2.0B separated 3x USB 2.0 HOST, 1x USB 2.0 OTG, 2x ETH 10/100, LCD Port, 1xHDMI, LVDS, 1x Mini PCIe (only USB), RTC, Temperature sensor, Reset-Button, SD interface, Power supply, 4 GB SD card, Cables

Starter kit STKa6ULx set

The core of the STKa6ULx set is the TQMa6ULx module with a Cortex-A7 CPU. The components contained in the starter kit constitute a modular system enabling you to develop your own product ideas. Development of graphic interfaces can be started immediately using the prepared combination of closed display unit and starter kit that are matched to each other. To develop your own hardware you can use the certified and qualified circuit components of the starter kit in your own designs.

TQ-Systems GmbH

Mühlstr. 2 | Gut Delling | 82229 Seefeld | Germany

Phone: +49 8153 9308-0 | Fax: +49 8153 4223

info@tq-group.com | www.tq-group.com

>> Quicklink: www.tq-group.com/en/TQMa6ULxL

Technology in Quality

